

Industrial Shredder – UNI-SHEAR® SR300

BRAND



UNI-SHEAR® SR300 single rotor shredder/grinder reduces bulky material in a single pass while producing predictable, small, consistent particles.

The technology of the Uni-Shear® SR300 offers a viable alternative to other traditional size reduction solutions. The SR300 uses an adjustable speed, pressure-sensing ram and individually replaceable, reversible cutters to effectively grind material to small consistent particles in a single pass.



PROCESS MATERIALS INCLUDING:

It can process up to 500 kg. / hour

- Paper/Cardboard
- Plastics (hard and soft)
- Foam
- Product destruction
- Mattress scrap
- Wood waste
- Pharmaceuticals
- Rubber
- Organic waste
- Light gauge metals
- Fibers/Textiles and more...

ADVANTAGES

- Interchangeable screens from 3/8" to 4" allow easy cleaning and particle size adaptation.
- Replaceable and reversible cutters extend uptime.
- Exclusive electric direct drive design (no belts).
- 'Smart' ram to fit different applications and materials.
- Operator-friendly, full function control panel.
- Ram and rotor loading interface allows efficient and automatic shredder operation.
- Robust construction and easy maintenance design.
- 1 cubic yard hopper for large volume, bulk feeding.



DESIGN CHARACTERISTICS

- Delivers consistent, uniform particle size in a single pass.
- Processes a variety of materials including plastics, fiber, paper, foam, wood waste and textiles.
- Allows operators to 'dump and run' batches of material.
- Reinforced in critical areas.
- Accepts up to 1 cubic yard of infeed material.
- Accepts bulk or meter (conveyor) fed loading.
- Meters shredded material to downstream equipment.
- Is configured specifically for your application.

Cont. on page 2

Please, contact us if you need more information or a detailed quote.

February 2018

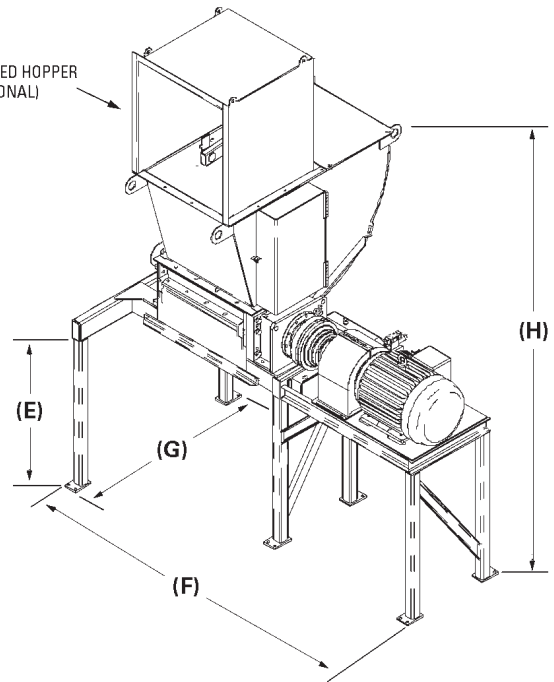
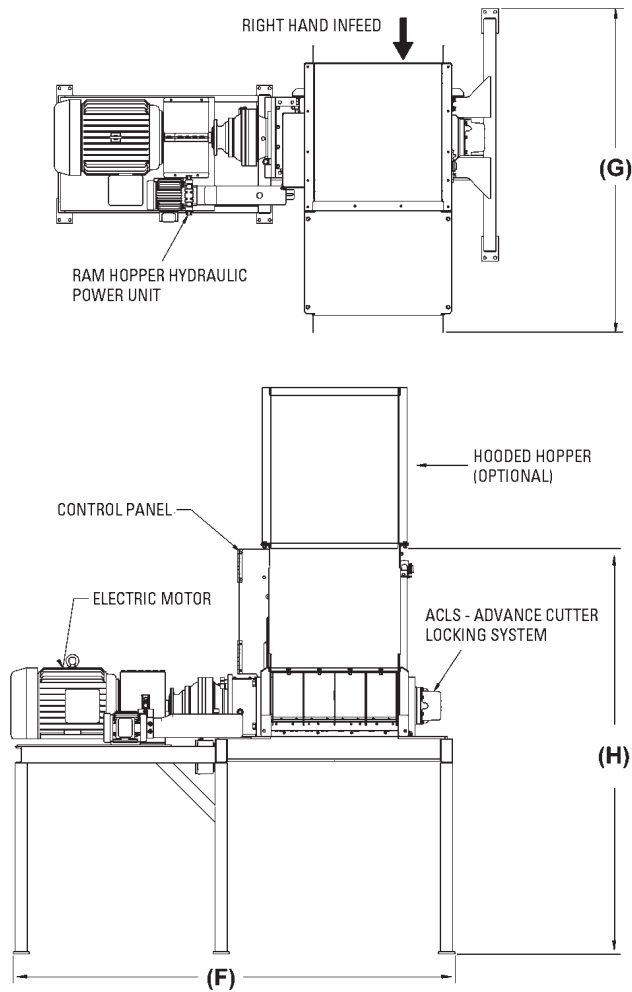

SPECIFICATIONS	UNI-SHEAR® SR300
HP Range	50HP (37kW)
Voltage	460/3/60 standard; other options available
Number of Cutters	36
Rotor Speed (rpm)	125
Screen sizes	3/8" - 4" (10-102 mm)
Cutter Tip diameter	12" (300 mm)
Active rotor length	31" (790mm)
Cutting chamber (WxL)	33" x 31" (840 mm x 785 mm)
Hopper Capacity	1 cu yd (0.76 cubic meters)
Discharge height (E)	47" 1,194 mm
Machine length (F)	108" (2,750 mm)
Machine width (G)	79" (2,005 mm)
Machine height (H)	101" (2,565 mm)
Machine weight (less HPU)	4,000 lbs. (1,800 kg)
Hydraulic ram	2HP (1kW)



MANUFACTURER'S NOTE: Illustrations, specifications and descriptions presented reflect standard product at time of publication and are subject to change without notice. Dimensions are approximate. Photographs may include optional equipment. Please, consult with your distributor.

Please, contact us if you need more information or a detailed quote.